

Introduction

LW103* is a super-regenerative amplitude-shift-keying (ASK) modulation (or On-Off keying, OOK) single chip receiver. It is designed to operate for low power device (LPD) applications. Industry commonly uses 315MHz, 433 MHz 886MHz and 915MHz for US and European markets for LPD applications. By changing a few external components, energy saving LW103 can support frequency band from 300MHz to 928MHz at low cost.

Features

- Frequency range from 300 MHz to 928 MHz
- High sensitivity
- Optional internal Low Noise Amplifier (LNA) for higher sensitivity
- Versatile configuration to accommodate various application with different requirements
- Low power consumption
- Operate from -20 °C to 70 °C
- Only require a few inexpensive external components
- Low cost
- QFN-20 package or die form for PCB bonding
- Custom made digital decoder is available for cost and space saving

Applications

- Remote controllers
- Security systems such as car alarm
- Wireless door bells
- Garage openers
- Radio controlled toys
- Monitoring systems
- RFID

Block Diagram

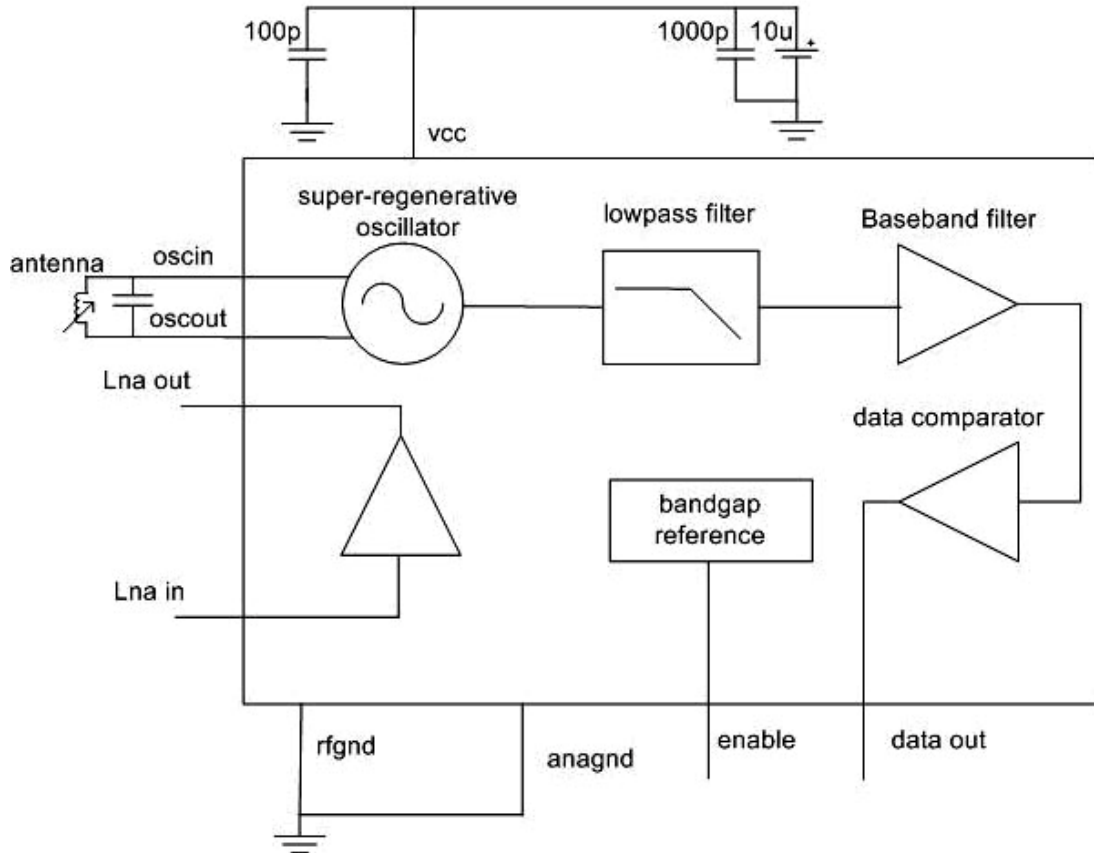

Pin Description

Pin no.	Symbol	Description
1	LNAOUT	LNA output
2	LNAIN	LNA input
3	LNAGND	LNA ground
4	FILOUT2	Second data filter output
5	FILOUT1	Data filter output
6	FILIN	Data filter input
7	OSCIN	RF oscillator input
8	OSCOUT	RF oscillator output
9	OSCGND	RF oscillator ground
10	RFGND	RF ground
11	COMPOUT	Data comparator output
12	COMPINP	Data comparator positive input
13	COMPINN	Data comparator negative input
14	AMPINN	Data amplifier negative input
15	AMPINP	Data amplifier positive input
16	VDD	Power supply
17	AMPOUT	Data amplifier output
18	ENABLE	Chip enable
19	BBOSC	Baseband oscillator
20	ANAGND	Analog ground

Electrical Characteristics

Maximum ratings

Rating	Symbol	Value	Unit
Power Supply Voltage	V_{BATT}	6	Vdc
RF Input Power	P_{max}	-20	dBm
Junction Temperature	T_J	125	°C
Storage Temperature Range	T_{STg}	-55 to 125	°C

Recommended Operating Conditions

Characteristics	Value	Unit
Supply voltage	2.5 – 3.3	V
RF frequency range	300 - 928	MHz
Max data rate	5	Kbps

DC Electrical Characteristics

Characteristics	Minimum	Typical	Maximum	Unit
Standby current	5	-	50	μA
Operating current				
With LNA	1.5	-	3	mA
Without LNA	0.7	-	2	
Input Low Voltage	$0.8 \cdot V_{dd}$	-	V_{dd}	V
Input High Voltage	V_{ss}	-	$0.1 \cdot V_{dd}$	V

AC Electrical Characteristics

Characteristics	Minimum	Typical	Maximum	Unit
Sensitivity (1KHz)	-	-100	-	dBm
with LNA (Direct RF IN)				
Stabilization time	-	100	-	ms

Functional Descriptions

LW103 is a super-regenerative receiver. The heart of the chip is an oscillator operating in super-regenerative mode. The demodulated baseband signal is filtered by a low pass filter. The filtered signal is then amplified by an operational amplifier. Since on-off keying is used, the amplifier signal will be compared with voltage reference at a data comparator. It will then recover the transmitted “0” and “1” sequence.

A bandgap reference is implemented inside the chip for stable operating conditions over temperature and supply voltage. In addition, our patent pending approach allows the chip operate normally from 2.5V to 3.3V and overcomes component variations. The chip is thus very suitable for mass production applications where no tight tolerance components are required.

An internal Low Noise Amplifier (LNA), as shown in application circuit A, can be used to achieve higher sensitivity and isolation to meet emission requirements. The signal isolation offered by the LNA also minimizes receiving sensitivity degradation when the oscillation frequency of the super-regenerative oscillator will be affected by a close object (hand-effect). In normal-sensitivity applications where hand-effect would not occur, the loop antenna (application circuit B) can be used as a resonator in the super-regenerative oscillator to save external components and current consumption as the LNA is not needed. Similarly, for applications that require only medium sensitivity, application circuit C would be suitable to eliminate the hand-effect with low current consumption.

Application Example (433MHz)

A. High Sensitivity and isolation with LNA

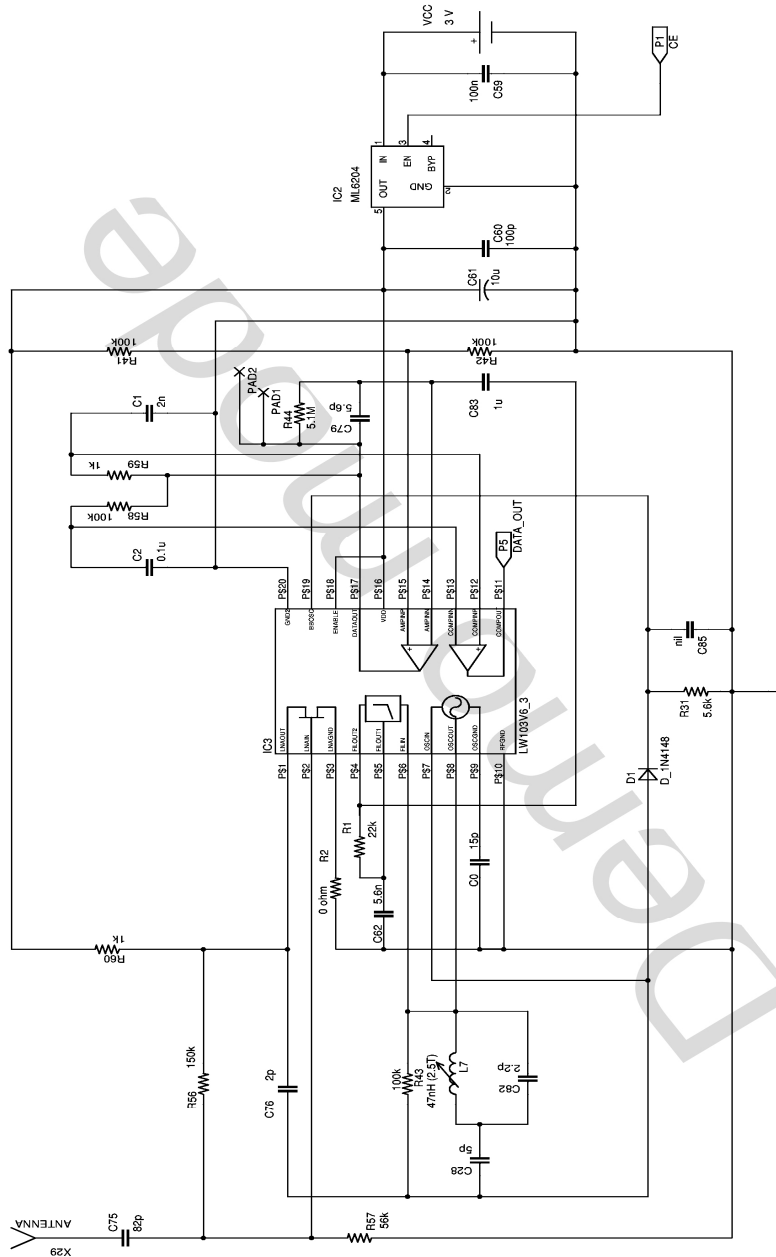

B. Normal Sensitivity with loop antenna, subject to hand-effect

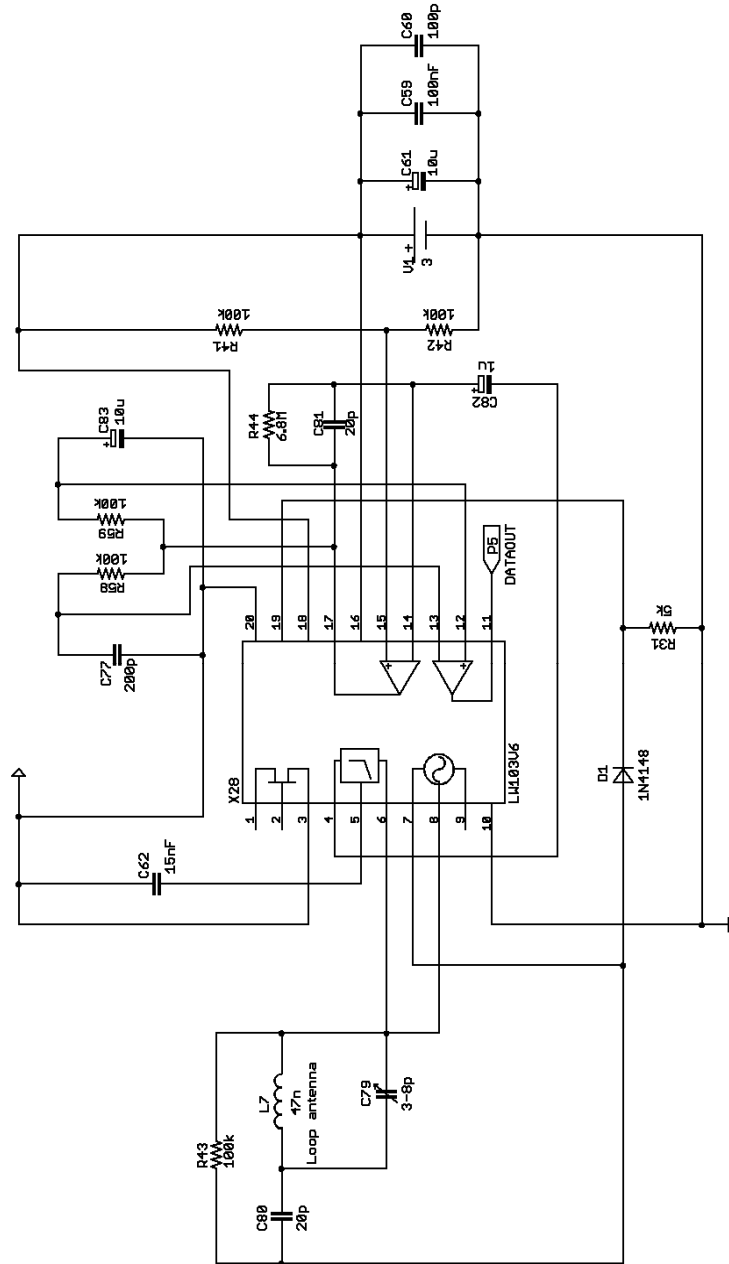

Component values optimized for 2.5 to 3.3V operation
 Normal sensitivity
 Patent pending

C. Medium sensitivity with less hand-effect

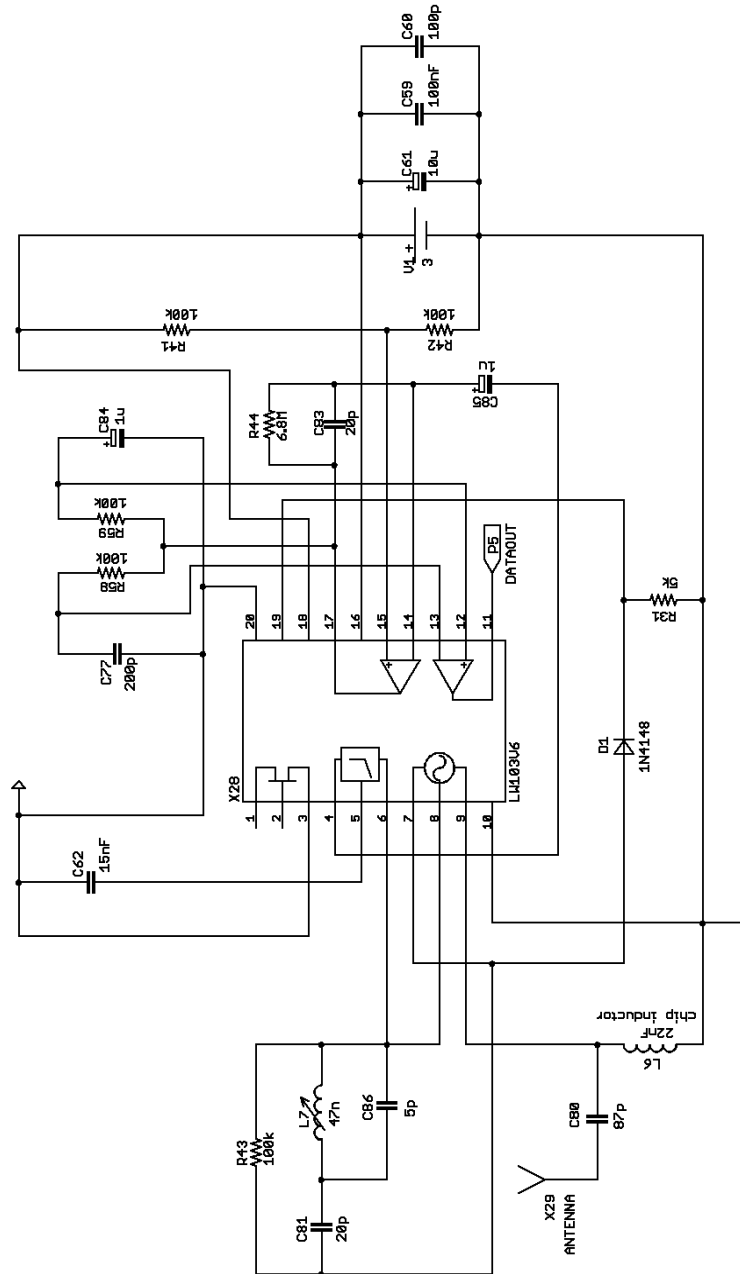

Component values optimized for 2.5 to 3.3V operation
 Medium sensitivity and less hand-effect
 Patent pending

Evaluation Board

- Based on application example A (High Sensitivity and isolation with LNA)

External Components:

Part	Value	Package
C76	2 pF	0603
C82	2.2 pF	0603
C28	5 pF	0603
C79	5.6 pF	0603
C0	15 pF	0603
C75	82 pF	0603
C60	100 pF	0603
C1	2 nF	0603
C62	5.6 nF	0603
C59,C2	100 nF	0603
C83	1 uF	0603
C61	10 uF	0805
R2	0 Ω	0603
R59,R60	1 k Ω	0603
R31	5.6 k Ω	0603
R1	22 k Ω	0603
R57	56 K Ω	0603
R41,R42,R43,R58	100 k Ω	0603
R56	150 k Ω	0603
R44	5.1 M Ω	0603
IC3	LW103	
L7	47 nH	2.5T for 433MHz
D1	1N4148	Lead or SMD
IC2	ML6204	LDO SMD
X29	---	Antenna

Remark: The suggested component values are optimized for 1KHz datarate. C1, C2 and C83 may be adjusted for different datarate and power-up settling time requirement. For detailed design information, please contact Lexiwave.

Typical Performance Characteristics

- Based on application example A (High Sensitivity and isolation with LNA)

Sensitivity at 315MHz (Fmod=1kHz)

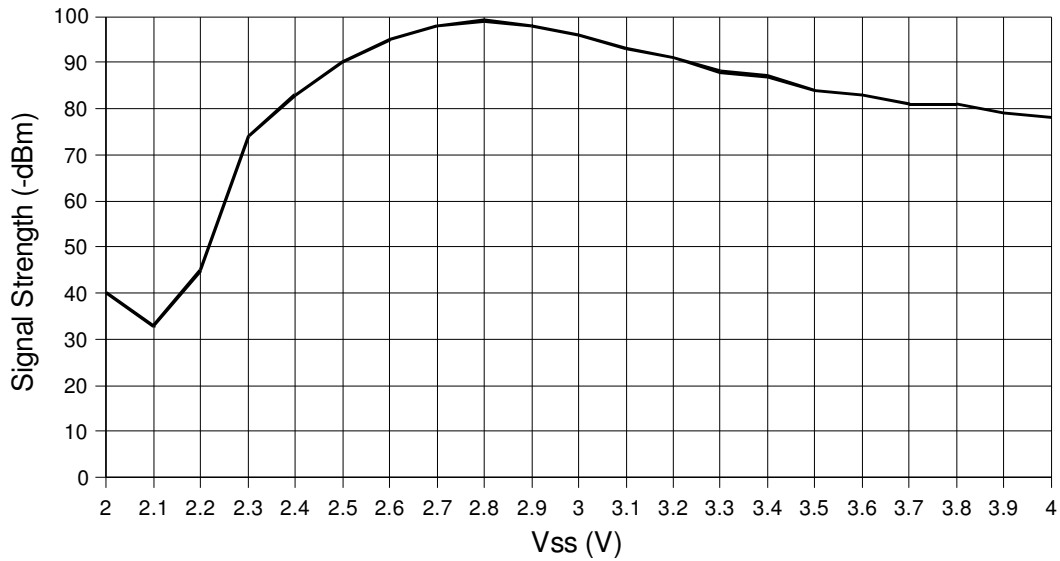

Current Consumption [Without LDO]

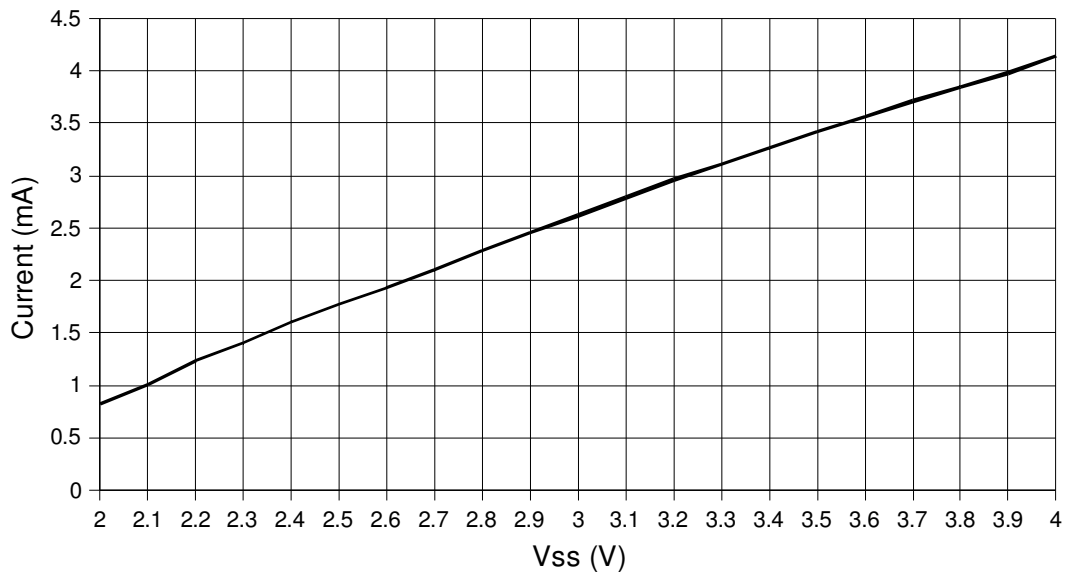

Selectivity at Vss = 3V (Fmod=1kHz)

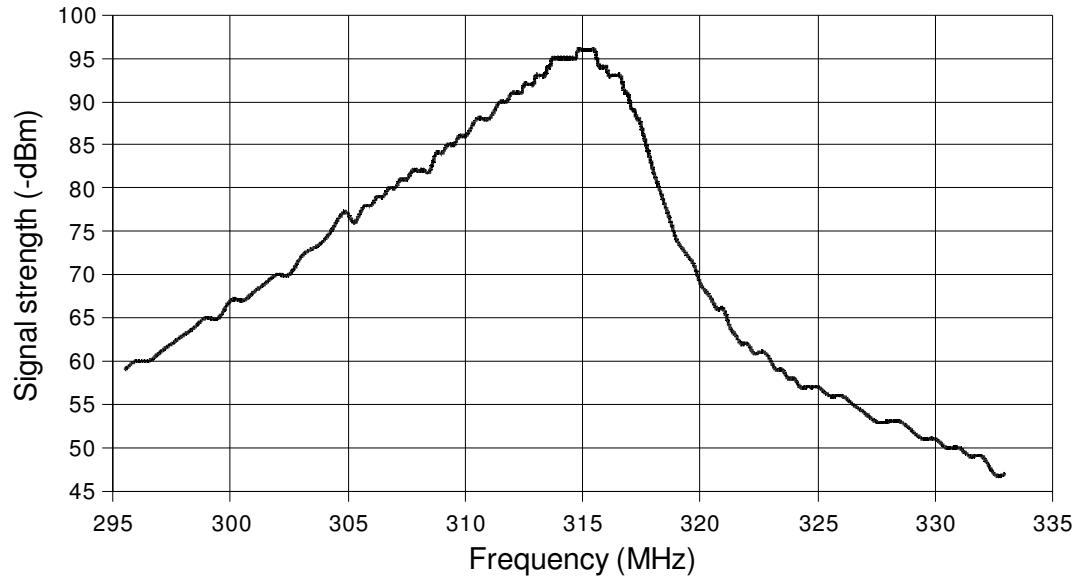

Selectivity at Vss = 3V (Fmod=1kHz)

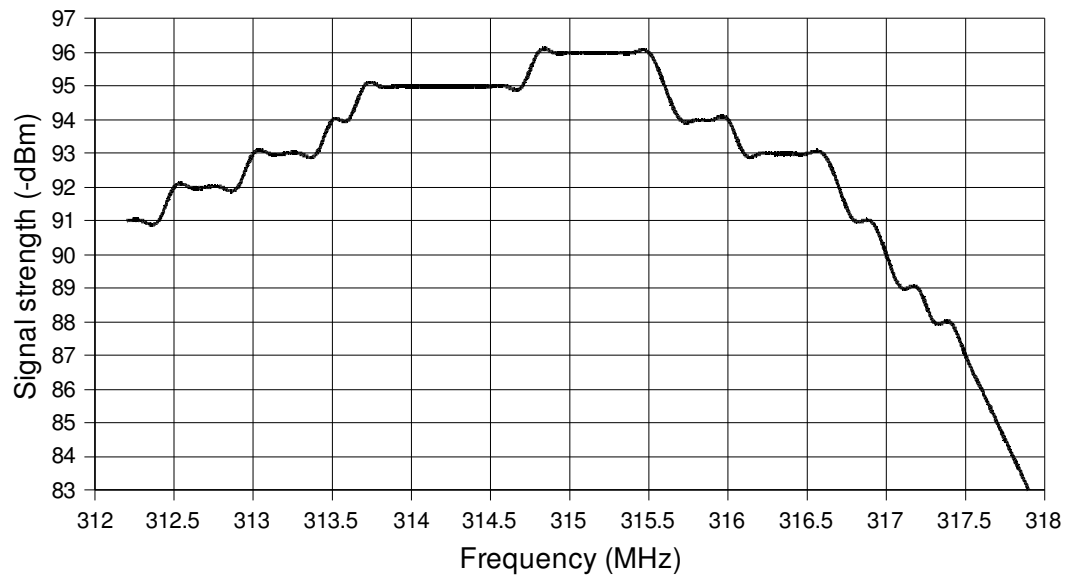

IMPORTANT NOTICE

The information presented in this document does not form part of any quotation or contract. Lexiwave Technology (Hong Kong) Ltd. (LW) does not assume any responsibilities for use of any circuitry described and no circuit patent licenses are implied. No liability will be accepted by LW for any consequence of its use. LW reserves the right to make changes to its products or to discontinue any integrated circuit product or service without notice.

A few applications using integrated circuit products may involve potential risks of death, personal injury, or severe property or environmental damage. LW integrated circuit products are not designed, intended, authorized, or warranted to be suitable for use in life-support applications, devices or systems or other critical applications. Use of LW products in such applications is understood to be fully at the risk of the customer.