

1.0 Introduction

The LW501 is a 150mA Low-Noise Low-Dropout Regulator with Chip Enable. Designed for used with very low ESR output Capacitors.

2.0 Features

- Low dropout voltage
60mV @ 30mA
200mV @ 100mA
- Guaranteed output current
150mA
- High output voltage accuracy
1.5V ~ 1.95V ± 3%
2.0V ~ 6.0V ± 2%
- Custom output voltage
1.5V ~ 6.0V
- Wide supply voltage range
10V max
- Low shut down quiescent current
0.1 μ A (Typ.)
- Low Power Consumption
70 μ A (Typ.)
- High Ripple Rejection
70dB (10kHz)
- Low Output Noise
30 μ Vrms
- Operating temperature
-40 ° C ~ +85 ° C
- Stable with low-ESR output capacitor

3.0 Applications

- Cordless Phone
- Palmtop/Laptop Computer
- Personal Digital Assistant
- Digital Camera
- Portable Multimedia Player
- Battery powered equipment
- Reference voltage

4.0 Pin Description

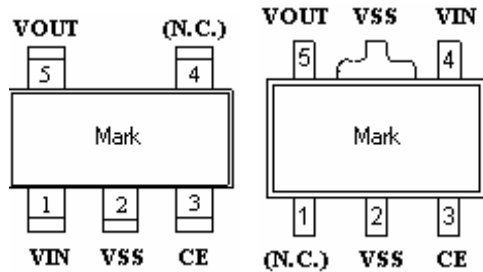

Pin No.		Symbol	Description
SOT-23-5	SOT-89-5		
1	4	VIN	Input
2	2	VSS	Ground
3	3	CE	ON/OFF Control
4	1	N.C.	No Connection
5	5	VOUT	Output

5.0 Electrical Characteristics

Parameter	Symbol	Conditions	Ta=25°C			-40°C≤Ta≤85°C			Units	Circuit
			Min	Typ	Max	Min	Typ	Max		
		IOUT = 30mA,								
			X0.97	VOUT(T)	X1.03	X0.96	VOUT(T)	X1.04		
Output Voltage	VOUT(E)	1.5V ≤VOUT(T) ≤1.95V							V	1
	IOUT = 30mA,									
			X0.98	VOUT(T)	X1.02	X0.97	VOUT(T)	X1.03		
		2.0V ≤VOUT(T) ≤6.0V								
Maximum Output Current	IOUT MAX		150			150			mA	1
Load Regulation	DVOUT	1mA ≤IOUT ≤ 100mA		15	50		30	80	mV	1
Dropout Voltage	Vdif1	IOUT = 30mA	E-1						mV	1
	Vdif2	IOUT = 100mA	E-2						mV	
Supply Current (C series)	IDD	VIN= VOUT(T) +1.0V, VCE=VSS	20	80	120	20	90	145	μA	2
	VIN= VOUT(T) +1.0V, VCE=VSS	20	70	100	20	80	120			
Standby Current	Istby	VIN=VCE=OUT(T)+1.0V		0.01	0.10		0.05	1.00	μA	2
Line Regulation	DVOUT	VOUT(T)+1.0V ≤VIN ≤10V		0.01	0.20		0.05	0.30	%V	1
	DVIN-VOUT	IOUT=30mA								
Input Voltage	VIN		2		10	2		10	V	
Output Voltage Temp. Characteristics	DVOUT DTopr-VOUT	IOUT=30mA -40°C ≤Topr ≤ 85°C		100					Ppm/ ° C	1
Output Noise	en	IOUT=10mA 300Hz ~ 50kHz		30					μVrms	3
Ripple Rejection Rate	PSRR	VIN=[VOUT(T)+1.0]V+1.0Vp-pAC IOUT=50mA, f=10kHz		70					dB	4

Current Limited	ILim	VIN=VOUT(T)+1.0V, VCE=VSS	300			280		mA	1
Short-circuit Current	Ishort	VIN=VOUT(T)+1.0V, VCE=VSS	50			60		mA	1
CE "High" Voltage	VCEH		1.6	VIN	1.7		VIN	V	1
CE "Low" Voltage	VCEL			0.25			0.20	V	1
CE "High" Current	ICEH	VIN=VCE=VOUT(T)+1.0V	-0.10	0.10	-0.15		0.15	μA	2
CE "Low" Current (C series)	ICEL	VIN =VOUT(T)+1.0V, VCE=VSS	-20	0.10	-25		0.15	μA	2
CE "Low" Current (D series)	ICEL	VIN =VOUT(T)+1.0V, VCE=VSS	-0.10	0.10	-0.15		0.15	μA	2

Note:

(NOTE 1) Unless otherwise stated , $V_{IN} = V_{OUT}(T) + 1.0V$

(NOTE 2) $V_{OUT}(T)$ =Specified Output Voltage

(NOTE 3) $V_{OUT}(E)$ = Effective Output Voltage (i .e. the output voltage when " $V_{OUT}(T)+1.0V$ " is provided at the VIN pin while maintaining a certain IOUT value)

(NOTE 4) $V_{dif} = (V_{IN1} (NOTE 6) - V_{OUT1} (NOTE5))$

(NOTE 5) V_{OUT1} = A voltage equal to 98% of the Output Voltage whenever an amply stabilized IOUT ($V_{OUT}(T)+1.0V$) is input.

(NOTE 6) V_{IN1} =The Input Voltage when V_{OUT1} appears as Input Voltage is gradually decreased.

(NOTE 7) The values for $-40^{\circ}C \leq T_{opr} \leq 85^{\circ}C$ are designed values.

6.0 Functional Descriptions

LW501 series are highly precise, low noise; positive voltage LDO regulators manufactured using CMOS processes. The device achieves high ripple rejection and low dropout. The output voltage is selectable in 50mV increments within a range of 1.5V to 6.0V. The device is also compatible with low ESR ceramic capacitors which give added output stability. This stability can be maintained even

Lexiwave Technology (Hong Kong) Ltd.

www.lexiwave.com

LW501 150mA Low-Noise Low-Dropout Regulator

Preliminary Data Sheet

Subject to change without prior notice

during load fluctuations due to the excellent transient response of the device. The device has an integrated current limiter, which also operates as a short protection for the output pin. The CE function enables the output to be turned off, resulting in greatly reduced power consumption.



Rev 1.0, December, 2008

7.0 Block Diagram Typical Application

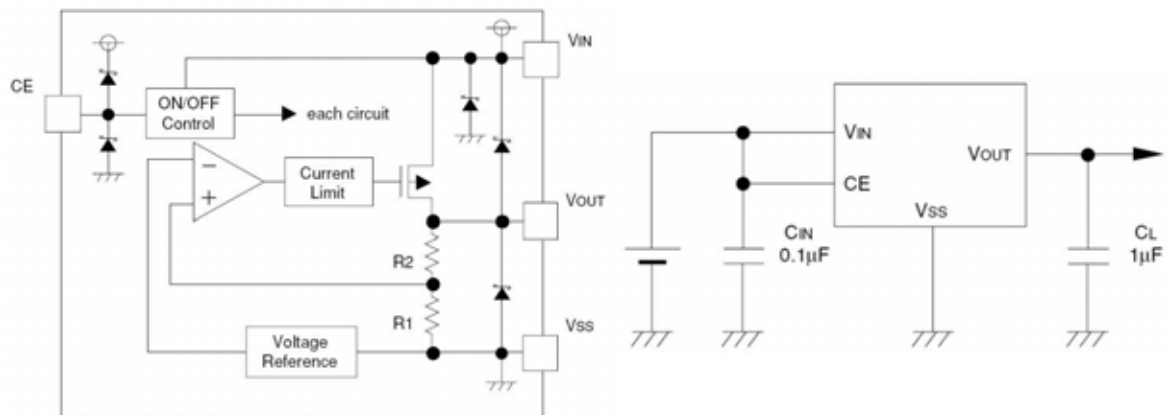

8.0 PACKAGE AND REEL DIMENSIONS

- SOT-89-5 package and reel dimensions

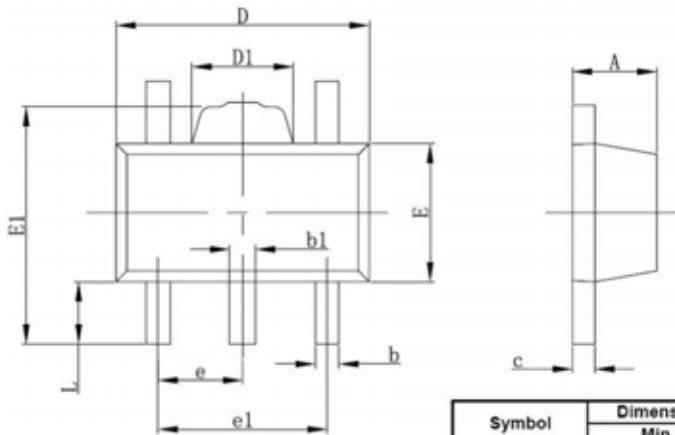

Symbol	Dimensions In Millimeters		Dimensions In Inches	
	Min	Max	Min	Max
A	1.400	1.600	0.055	0.063
b	0.320	0.520	0.013	0.020
b1	0.360	0.560	0.014	0.022
c	0.350	0.440	0.014	0.017
D	4.400	4.600	0.173	0.181
D1	1.400	1.800	0.055	0.071
E	2.300	2.600	0.091	0.102
E1	3.940	4.250	0.155	0.167
e	1.500TYP		0.060TYP	
e1	2.900	3.100	0.114	0.122
L	0.900	1.100	0.035	0.043

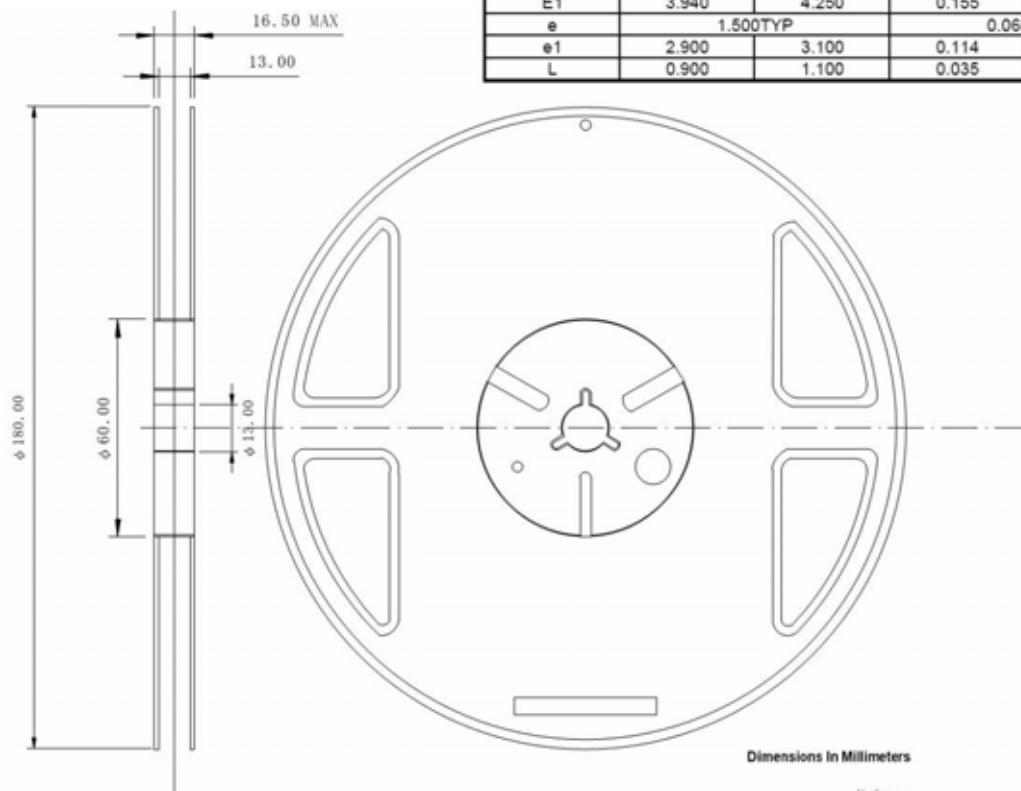

Taping

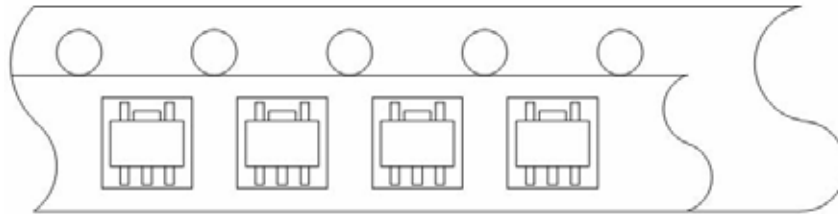
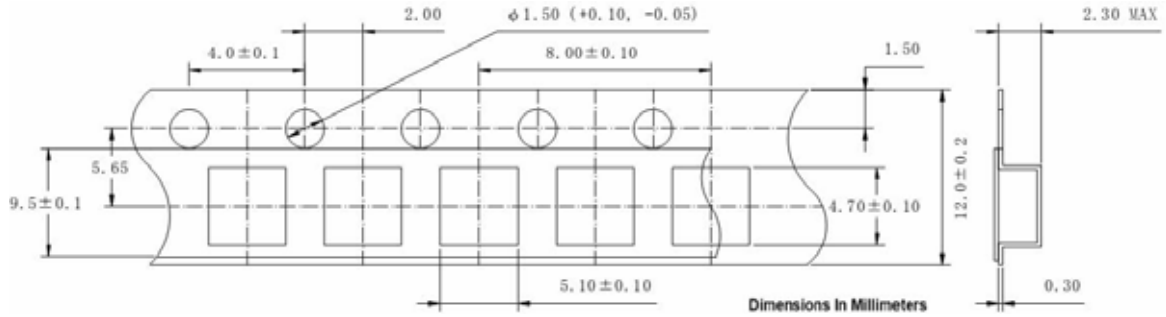

S Type : standard

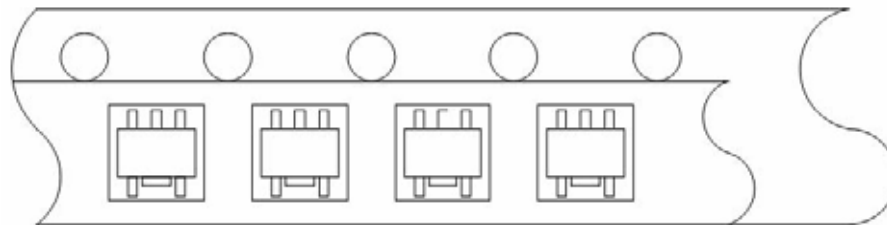

N Type : Reverse

9.0 Typical Performance Characteristics

Output voltage VS Output current

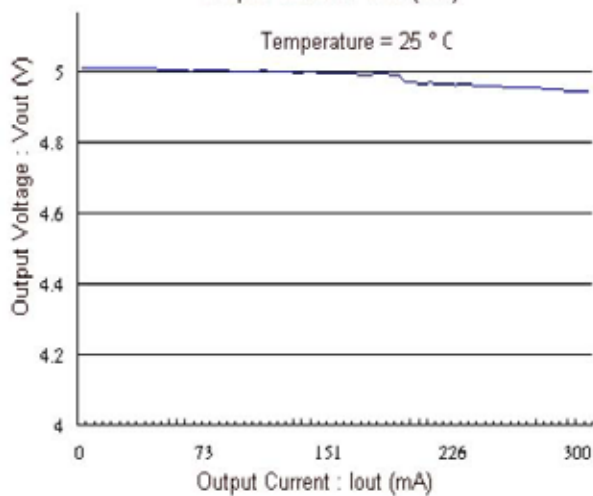
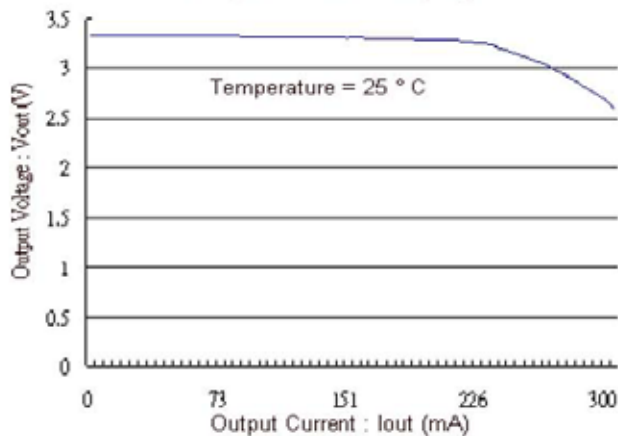
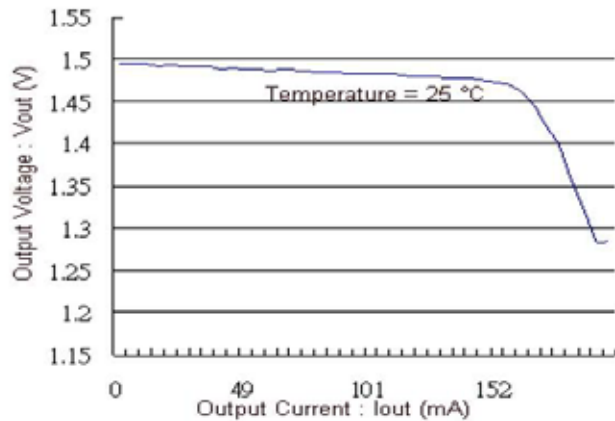

■ Output voltage VS Input voltage

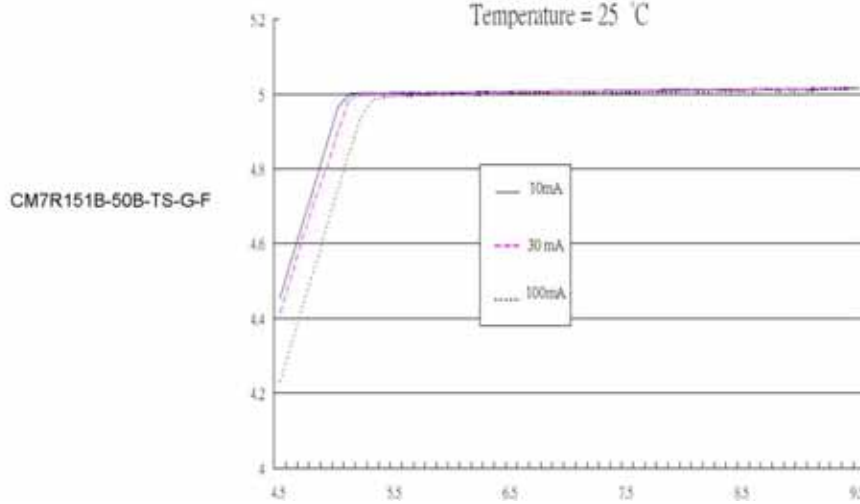
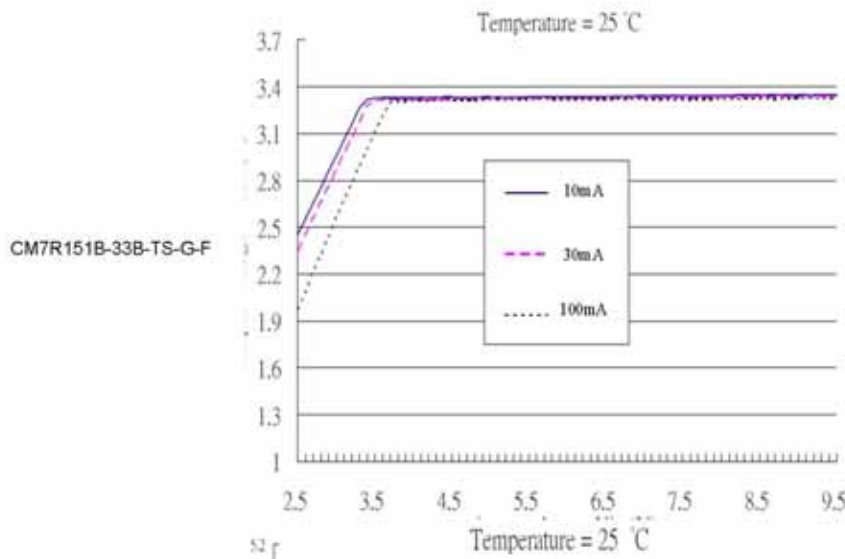
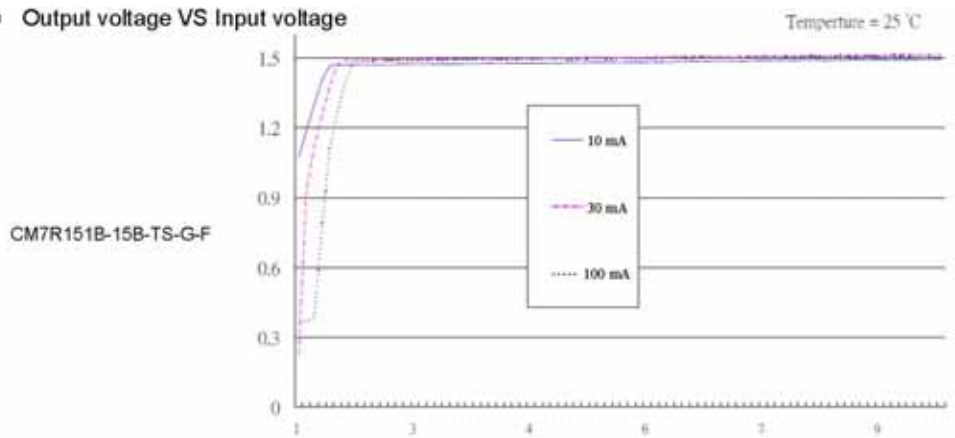

10.0 Selection Guide

The output voltage, version, and the taping type for the ICs can be selected at the user's request.

The selection can be made with designating the part number as shown below:

e.g. LW501A - 30 A - TS - G - F

Part number	LW501	<u>A</u> -	<u>30</u>	<u>A</u> -	<u>T</u>	<u>S</u> -	<u>G</u> -	<u>F</u>	→	3.05V ± 2% LDO with active high chip enable and a built in pull-down resistor on a version F silicon core packaged with lead free SOT23-5 package and put inside an embossed tape in standard feed form
		1	2	3	4	5	6	7		

Designator	Description	Symbol	Values
1	Pull up *	A	Active "High" (pull-down resistor built in)
		B	Active "High" (no pull-down resistor built in)
		C	Active "Low" (pull-down resistor built in)
		D	Active "Low" (no pull-down resistor built in)
2	Output voltage	15 ~ 60	Ex : 30 ⇒ Vout = 3.0V 18 ⇒ Vout = 1.8V
3	Voltage step size	A	50mV increments : ±2% accuracy Ex : 3.0V @ 2 ⇒ Vout = 3.05V ±2%
		B	100mV increments : ±2% accuracy Ex : 3.0V @ 2 ⇒ Vout = 3.0V ±2%
4	Package type	T	SOT 23 - 5
		P	SOT 89 - 5
5	Reel type	S	Embossed Tape : Standard feed
		N	Embossed Tape : Reverse feed
6	Lead free package	G	Missing label ⇒ non-lead free package
7	Version number	A ~ F	Latest version is F : March 2006

* The following options for the CE pin logic and internal pull-up/down are available:
 Active 'High' + no pull-down resistor built-in (standard)
 Active 'High' + 800kΩ pull-down resistor built-in <between CE-VSS> (semi-custom)
 Active 'Low' + no pull-up resistor built-in (semi-custom)
 Active 'Low' + 800kΩ pull-up resistor built-in <between CE-VCC> (semi-custom)

Note: *With the pull-up resistor or pull-down resistor built-in types, the supply current during operation will increase by $V_{IN} / 800k\Omega$ (Typ.)

11.0 IMPORTANT NOTICE

The information presented in this document does not form part of any quotation or contract. Lexiwave Technology (Hong Kong) Limited (Lexiwave) does not assume any responsibilities for use of any circuitry described and no circuit patent licenses are implied. No liability will be accepted by Lexiwave for any consequence of its use. Lexiwave reserves the right to make changes to its products or to discontinue any integrated circuit products or services without notice.

A few applications using integrated circuit products may involve potential risks of death, personal injury, or severe property or environmental damage. Lexiwave's integrated circuit, module or any other products are not designed, intended, authorized, or warranted to be suitable for use in life-support applications, devices or systems or other critical applications. Use of Lexiwave's products in such applications is understood to be at the full risk of the customer.