

## 1.0 Introduction

LW203M is an AM transmitter module using Lexiwave's LW203 RFIC designed for ASK communication systems. It consists of a Colpitts oscillator together with a RF power amplifier. Targeted applications are in the frequency band from 300MHz to 928MHz. By using an appropriate SAW resonator, LW203M can support both 315/433MHz and 886/915MHz UHF bands for ASK communication at low cost without any tuning. For 915MHz frequency, using variable inductor or micro-strip line as a resonator offers super low-cost solutions for short to medium communication range applications. It is a complementary module to Lexiwave's LW103M ASK receiver module to form a complete RF solution for ASK communication. A communication range of 150 meter in open area is typical.

## 2.0 Features

- Frequency range from 300 MHz to 900 MHz
- Low power consumption
- Operate from -20°C to 85 °C
- Small size, 26mm x 18mm
- No tuning and no programming using SAW resonator
- Low cost

### 3.0 Applications

- 315/433MHz or 886/915MHz Band Systems
- Remote controllers
- Security systems such as car alarm
- Wireless door bell
- Garage opener
- radio controlled toys
- Monitoring systems
- Local Oscillator Source
- Remote Fan/Light Control

**PCB Top View**

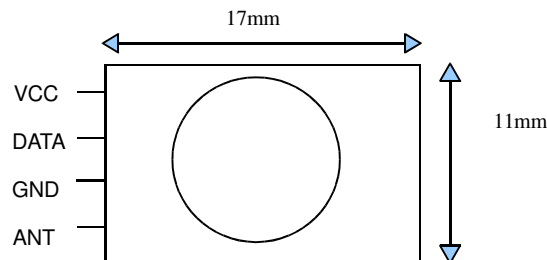

**Side View**

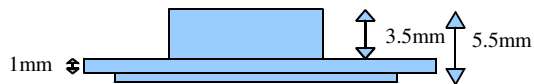

### 4.0 Pin Description

Pin no.	Symbol	Description
1	ANT	Antenna output
2	GND	Ground
3	DATA	Data Input
4	VCC	Vcc power input

## 5.0 Electrical Characteristics

### 5.1 Maximum ratings

Rating	Symbol	Value	Unit
Power Supply Voltage	$V_{BATT}$	6	Vdc
Junction Temperature	$T_J$	125	°C
Storage Temperature Range	$T_{STg}$	-55 to 125	°C

### 5.2 Recommended Operating Conditions

Characteristics	Value	Unit
Supply voltage	2.8 – 5	V
RF frequency range	300 – 928	MHz

### 5.3 DC Electrical Characteristics

Characteristics	Minimum	Typical	Maximum	Unit
Operation current (433MHz)	7	-	20	mA
Operation current (915MHz)	10	-	35	mA

## 5.4 AC Electrical Characteristics at 3V

Characteristics	Minimum	Typical	Maximum	Unit
Output Power (at 50 ohm) 433MHz	-	6	-	dBm
Harmonic suppression 433MHz		-40		dBc
Output Power (at 50 ohm) 915MHz	-	5	-	dBm
Harmonic suppression 915MHz		-40		dBc

## 6.0 Functional Descriptions

LW203M includes a RF oscillator and output power amplifier. Using an appropriate SAW resonator, the RF oscillator can be configured as a Colpitts oscillator to form a tuning-free and highly stable RF oscillator at 315/433/886/915 MHz. For 915MHz, using variable inductor or micro-strip line as a resonator offers super low cost solution for short to medium communication-range applications. The output power of the Colpitts oscillator is about -2 dBm at 50 ohm load. ASK modulation can be accomplished by applying digital data at the data input pin. The RF power amplifier is connected to the Colpitts oscillator output. The power amplifier also serves as an isolation buffer to minimize frequency pulling or oscillation degradation due to the near-object effect at the antenna.

## 7.0 Schematic

315/433/866/915 MHz ASK Transmitter module using SAW resonator

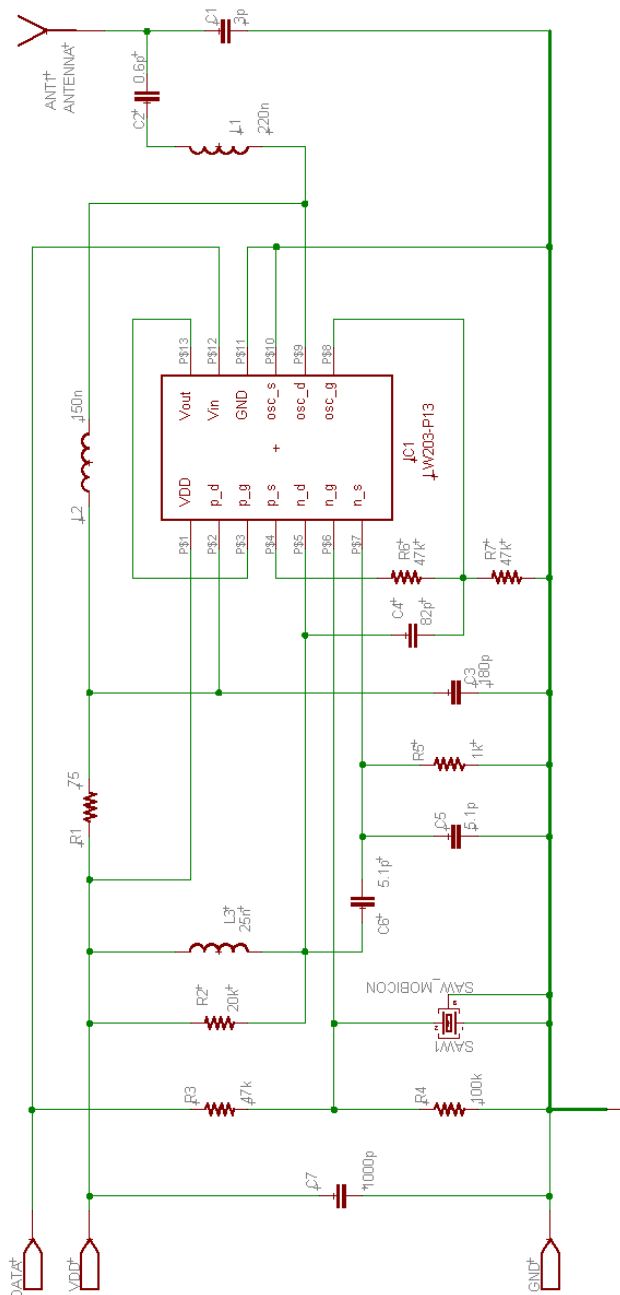

## 8.0 PCB layout

### 8.1 PCB Top layer (17 x 11 x 1 mm)

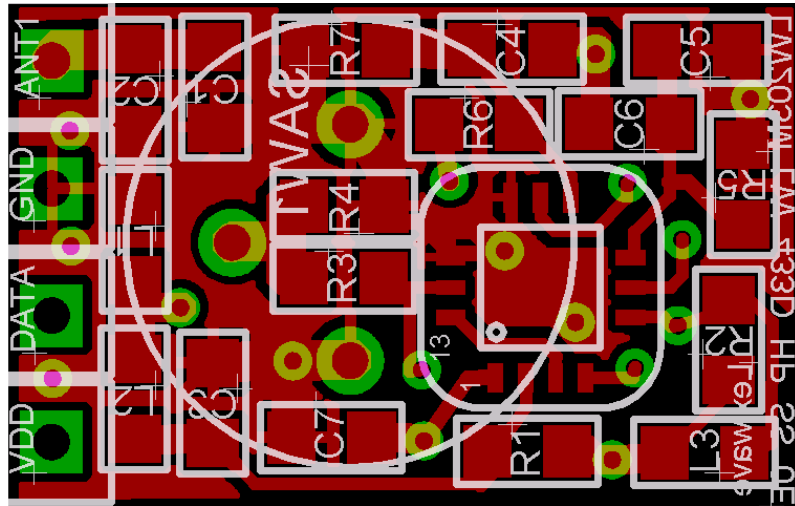

### 8.2 LW203M PCB bottom layer

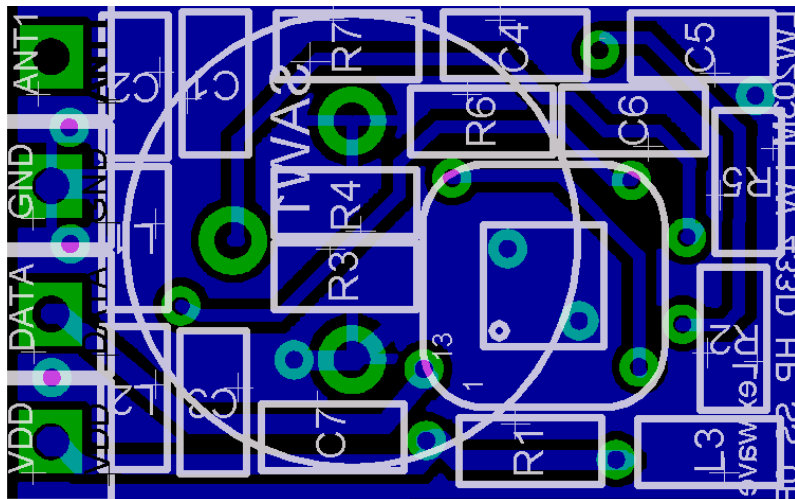

**External Components:**

<b>Part</b>	<b>Value</b>	<b>Package</b>
C2	0.6 pF	0603
C1	3 pF	0603
C5,C6	5.1 pF	0603
C4	82 pF	0603
C3	180 pF	0603
C7	1000pF	0603
R1	75 $\Omega$	0603
R5	1 k $\Omega$	0603
R2	20 k $\Omega$	0603
R3 , R6 , R7	47 k $\Omega$	0603
R4	100 K $\Omega$	0603
L3	25 nH	0603
L2	150 nH	0603
L1	220 nH	0603
SAW	433.92 MHz	
X29	---	Antenna

## 9. Selection guide

Part number	Resonator Type	Power	Cost	Application
LW203M-XXX-SA	SAW	+5dBm (915MHz)	affordable	weather station, door bell, monitoring system, car alarm
LW203M-XXX-LC	LC	+5dBm (915MHz)	low	radio controlled toys, remote controller, multi-frequency & multi-player toys
LW203M-XXX-ML	Microstrip	+5dBm (915MHz)	very low	radio-controlled toys, wireless mouse
LW203M-XXX-MN	Microstrip	-10dBm (915MHz)	super low	short-range radio-controlled toys

### Remark:

1. XXX is frequency code (in MHz): 315, 433, 868 and 915
2. LC, ML and MN version are only available at 868 and 915MHz

## 10 IMPORTANT NOTICE

The information presented in this document does not form part of any quotation or contract. Lexiwave Technology (Hong Kong) Limited (Lexiwave) does not assume any responsibilities for use of any circuitry described and no circuit patent licenses are implied. No liability will be accepted by Lexiwave for any consequence of its use. Lexiwave reserves the right to make changes to its products or to discontinue any integrated circuit products or services without notice.

A few applications using integrated circuit products may involve potential risks of death, personal injury, or severe property or environmental damage. Lexiwave's integrated circuit, module or any other products are not designed, intended, authorized, or warranted to be suitable for use in life-support applications, devices or systems or other critical applications. Use of Lexiwave's products in such applications is understood to be at the full risk of the customer.